

Name: \_\_\_\_\_ ( )

Class: Primary 6 \_\_\_\_\_

**Primary 6**  
**Continual Assessment 1 – 2017**  
**SCIENCE**  
**BOOKLET A**

**2 March 2017**

**Total Time for Booklets A and B: 1 hour 45 minutes**

**28 questions**

**56 marks**

**Do not open this booklet until you are told to do so.**

**Follow all instructions carefully.**

**Answer all questions.**

*This booklet consists of 18 printed pages.*



**Section A (28 x 2 marks = 56 marks)**

For each question from 1 to 28, four options are given. One of them is the correct answer. Make your choice (1, 2, 3 or 4). Shade the correct oval (1, 2, 3 or 4) on the Optical Answer Sheet provided.

1. The diagram below shows how water and food are transported in a plant.

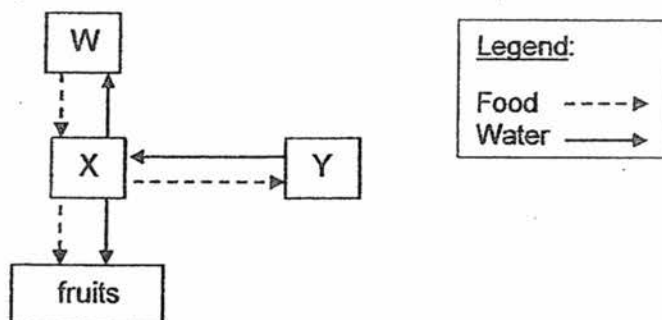

What plant parts do W, X and Y represent?

|     | W      | X      | Y      |
|-----|--------|--------|--------|
| (1) | roots  | stem   | leaves |
| (2) | stem   | leaves | roots  |
| (3) | leaves | stem   | roots  |
| (4) | leaves | roots  | stem   |

2. The diagram below shows how blood travels in the human body. Arrows A, B, C, D, E and F represent the movement of blood.

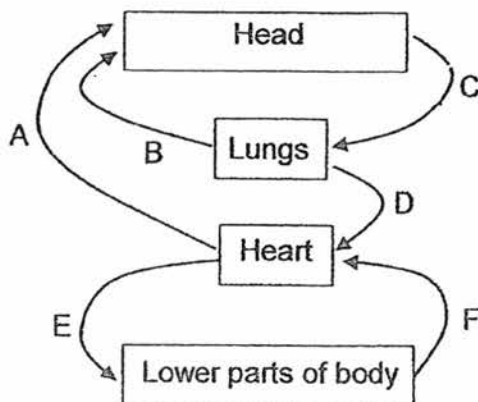

Which arrows in the above diagram are not correct?

- (1) A and E only
- (2) B and C only
- (3) A, C and D only
- (4) A, D, E and F only

3. A group of students built a model of the human respiratory system as shown below.

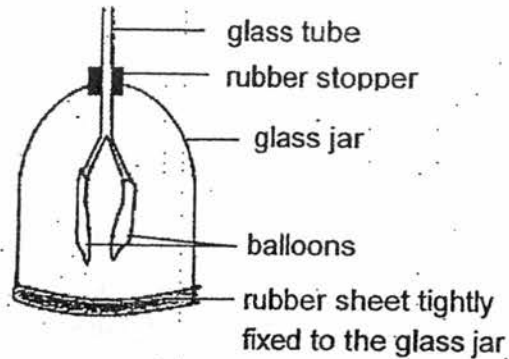

Which of the following cannot be represented by the model when the rubber sheet is pulled down?

- A The movement of the ribs during breathing.
- B The lungs being inflated when air is drawn in during breathing.
- C The movement of the diaphragm when air is drawn in during breathing.
- D The exchange of gases in the air sacs when air is drawn in during breathing.

- (1) A and D only
- (2) C and D only
- (3) A, B and C only
- (4) A, C and D only

4. An experiment using one of the leaves on a plant was set up as shown below. After 8 hours in the sun, the leaf was cut into three sections P, Q and R and tested for starch.

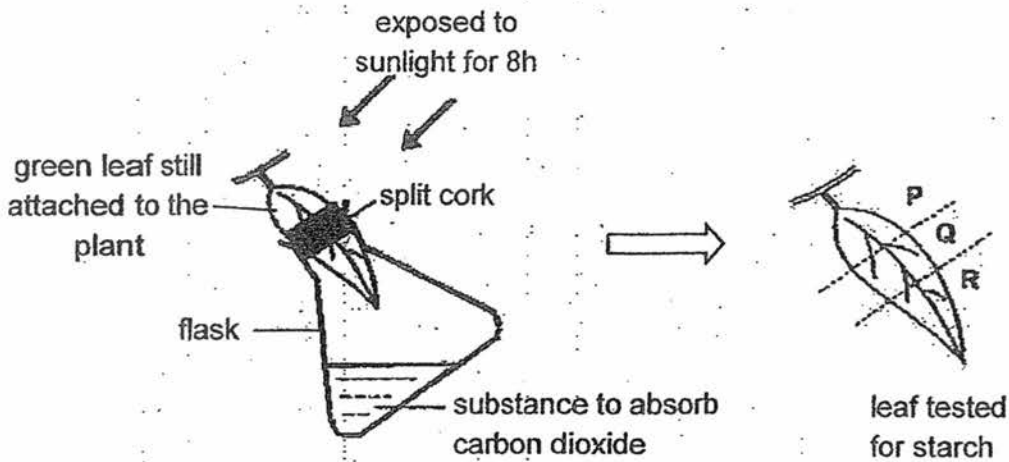

Which one of the following shows the results of the iodine test on the parts of the leaf labelled P, Q and R respectively?

|     | P               | Q               | R               |
|-----|-----------------|-----------------|-----------------|
| (1) | Dark blue       | Yellowish brown | Dark blue       |
| (2) | Dark blue       | Yellowish brown | Yellowish brown |
| (3) | Yellowish brown | Dark blue       | Dark blue       |
| (4) | Yellowish brown | Dark blue       | Yellowish brown |

5. A balsam plant undergoes processes X and Y as shown.

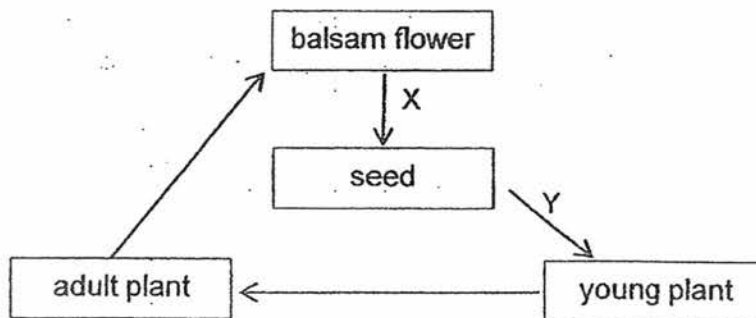

Which one of the following correctly represents the processes X and Y?

|     | X             | Y             |
|-----|---------------|---------------|
| (1) | fertilisation | germination   |
| (2) | pollination   | fertilisation |
| (3) | pollination   | dispersal     |
| (4) | germination   | dispersal     |

6. Study the flowchart below carefully.

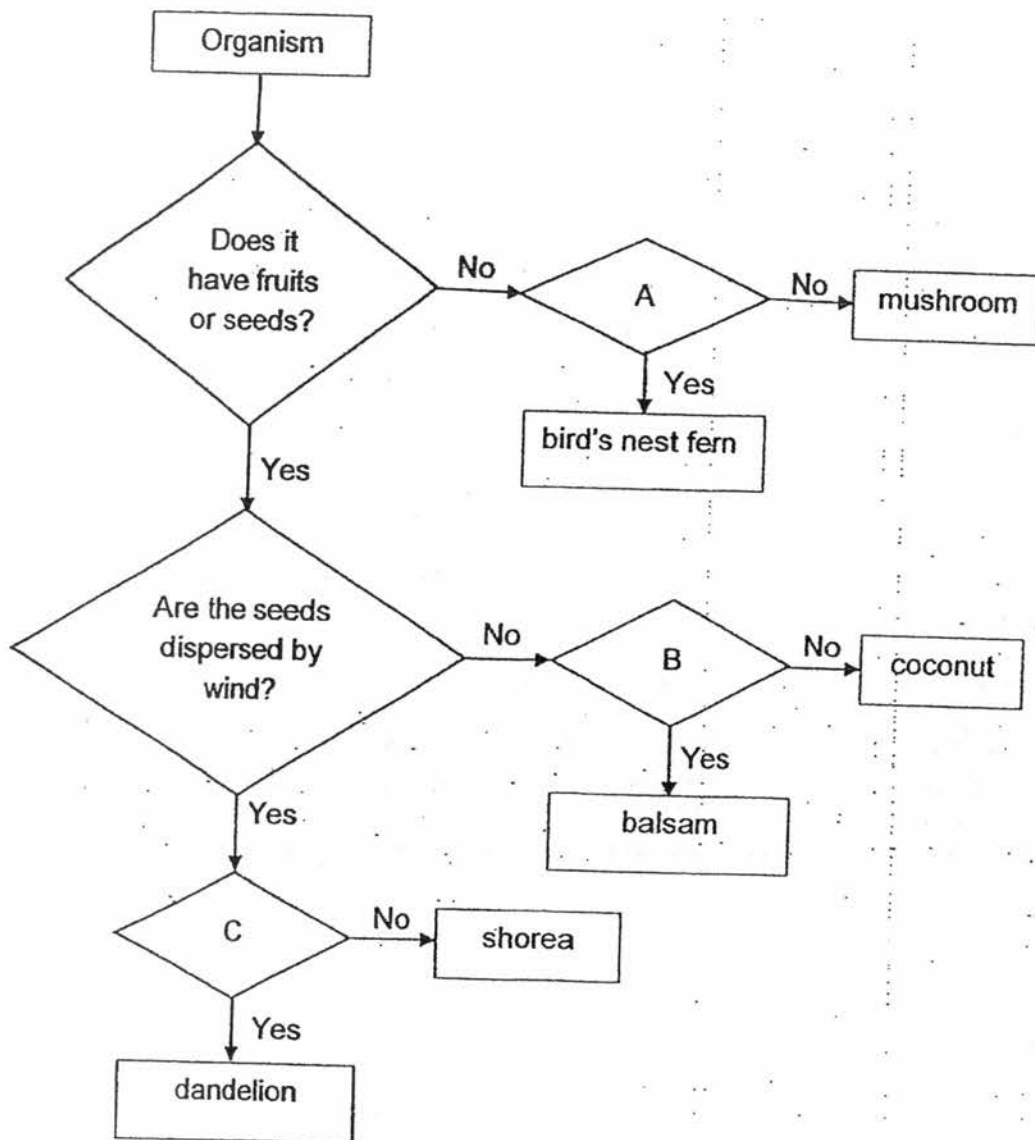

What do A, B and C in the flowchart represent?

|     | A                              | B  | C  |
|-----|--------------------------------|--|--|
| (1) | Does it grow in soil?          | Is the fruit wall fibrous?               | Does the fruit or seed have stiff hairs?         |
| (2) | Is it a plant?                 | Do the fruit walls split open when ripe? | Does the fruit or seed have hair-like structure? |
| (3) | Does it have spore bags?       | Is the fruit edible?                     | Does it have feather-like structure?             |
| (4) | Does it reproduce from spores? | Does it bear flowers?                    | Does the fruit/seed have wing-like structure?    |

7. Jenny wrote the following word equation that represents the process of photosynthesis:

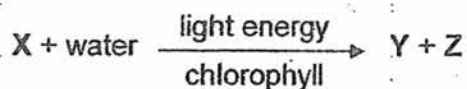

Which one of the following correctly represents X, Y and Z?

|     | X              | Y      | Z              |
|-----|----------------|--------|----------------|
| (1) | oxygen         | sugar  | carbon dioxide |
| (2) | oxygen         | starch | carbon dioxide |
| (3) | carbon dioxide | sugar  | starch         |
| (4) | carbon dioxide | sugar  | oxygen         |

8. John set up the experiment below to investigate the rate of photosynthesis.

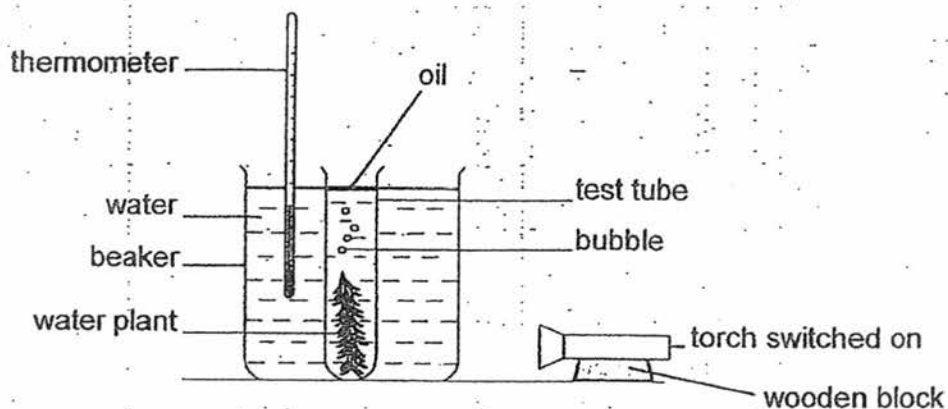

Which of the variables can affect the number of bubbles produced per minute by the plant?

- A the intensity of light
  - B the size of the leaves
  - C the temperature of water
  - D the amount of carbon dioxide in the beaker
- (1) A and B only  
 (2) C and D only  
 (3) A, B and C only  
 (4) A, B, C and D

9. The table below compares the sexual reproduction of flowering plants and humans.

|  | Flowering Plants | Humans         |
|--|------------------|----------------|
| The part where the male reproductive cell is produced/stored                           | Anther           | A              |
| The part where the male reproductive cell fuses with the female reproductive cell      | B                | Fallopian tube |
| The process whereby the male reproductive cell fuses with the female reproductive cell | C                | Fertilisation  |

Which one of the following correctly identifies A, B and C?

|     | A      | B      | C             |
|-----|--------|--------|---------------|
| (1) | Stigma | Ovary  | Germination   |
| (2) | Anther | Womb   | Pollination   |
| (3) | Testis | Ovary  | Fertilisation |
| (4) | Testis | Stigma | Pollination   |



10. Which one of the following correctly shows the path of light that allows George to read?

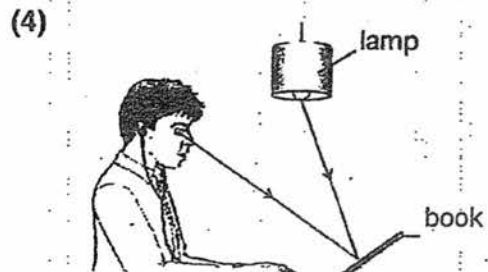
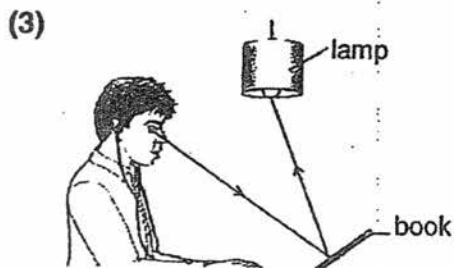
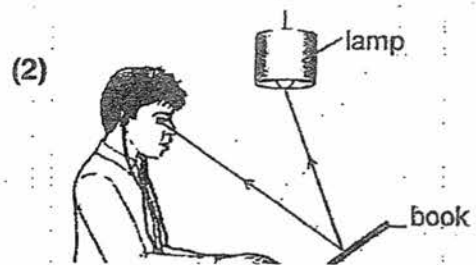
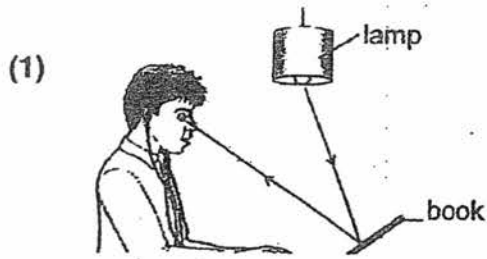

11. Which of the following statement(s) is/are true about using electricity safely?

- A Never touch switches with wet hands.
- B Do not put many plugs into one socket.
- C Try to repair exposed electrical wires by yourself.
- D Check electrical appliances regularly for exposed wires.

- (1) A only
- (2) B and C only
- (3) A, B and C only
- (4) A, B and D only

12. Kailing walked from position A to C, passing a lamp post at B.

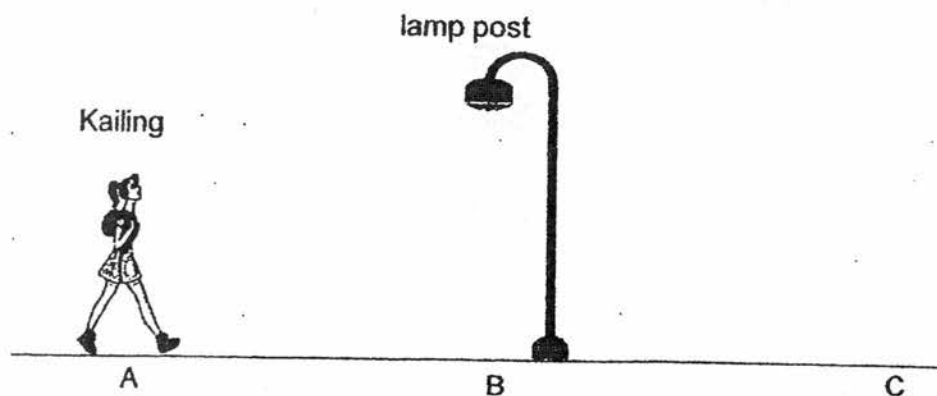

Which one of the following graphs shows how the length of her shadow changes as she walks from A to C?

(1)

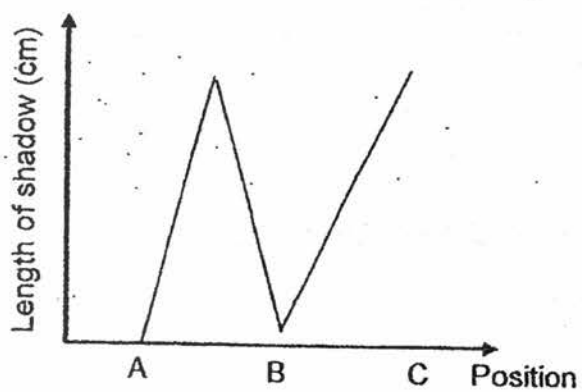

(2)

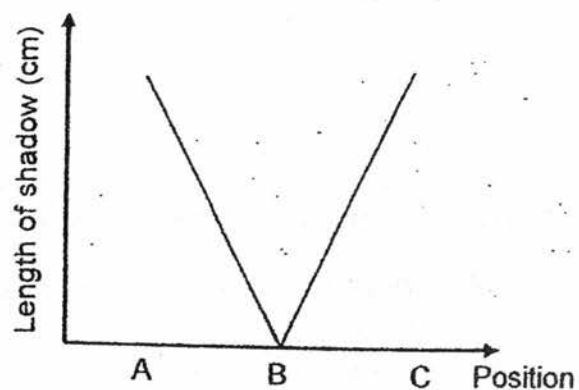

(3)

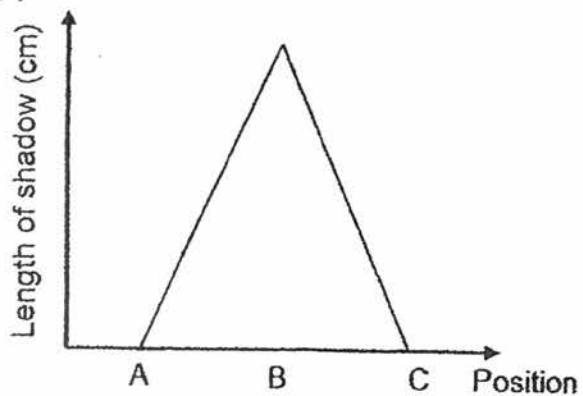

(4)

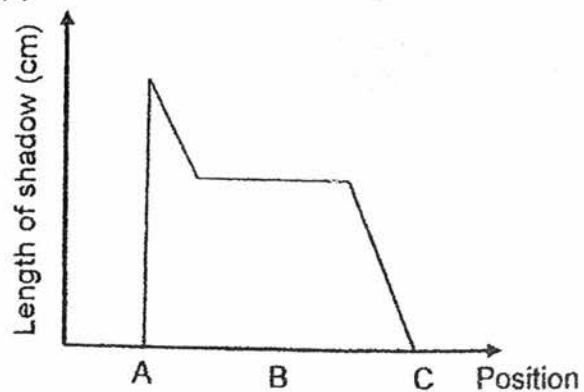

13. Ali set up a circuit as shown below.

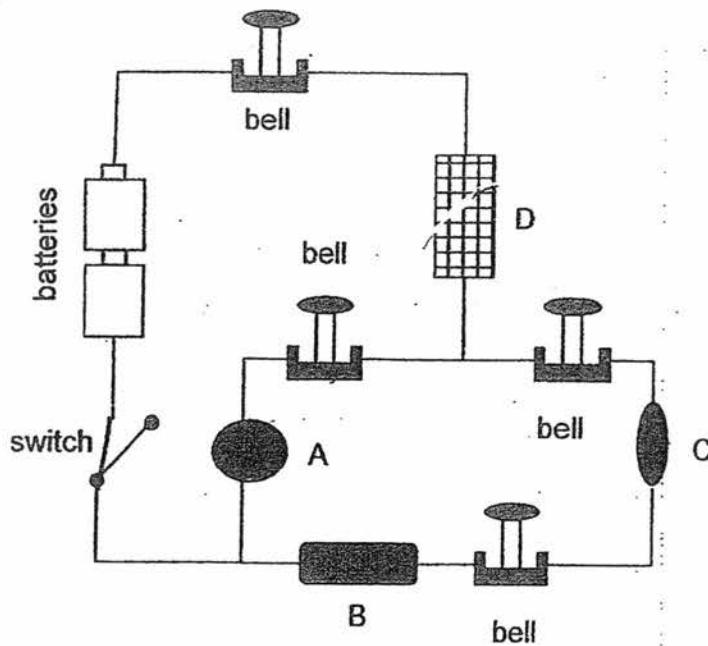

When the switch is closed, he observed that only two bells in the circuit rang. Which of the four objects A, B, C and D are electrical insulators?

- (1) A only
- (2) D only
- (3) A and B only
- (4) B and C only

14. The diagram below shows the front view of a circuit board.

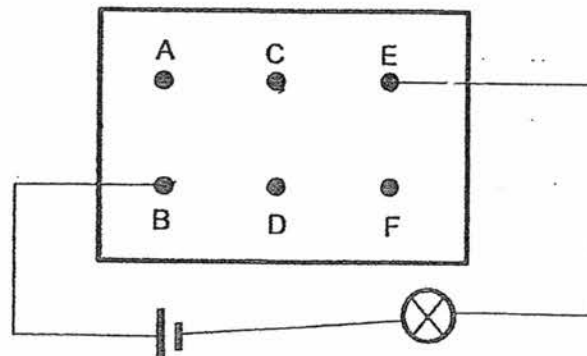

There are wires connected behind the circuit board which allow the bulb to light up. Which one of the following is a possible connection on the circuit board?

- (1) AB and CF
- (2) BC and CE
- (3) BD and EF
- (4) AD and ED

15. In the diagram below, 4 similar glasses, A, B, C and D, with equal amount of water at different temperatures were placed in a room with a temperature of 29 °C.

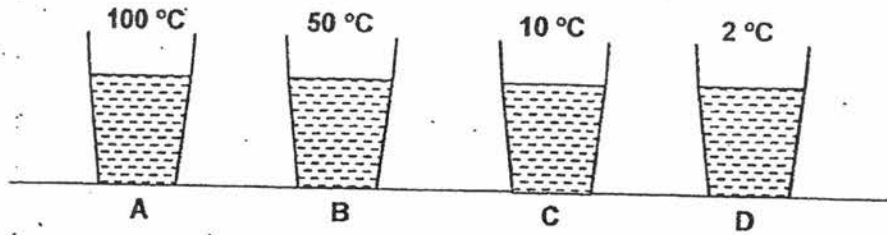

Water droplets were formed on the surfaces of the glasses after some time. On which surface of the glasses A, B, C and D will the water droplets be formed?

|     | A             | B             | C             | D             |
|-----|---------------|---------------|---------------|---------------|
| (1) | outer surface | outer surface | inner surface | inner surface |
| (2) | outer surface | outer surface | outer surface | outer surface |
| (3) | inner surface | inner surface | outer surface | outer surface |
| (4) | inner surface | outer surface | inner surface | outer surface |

16. Paul completely filled two identical syringes, one with air while the other with water as shown in the diagram below.

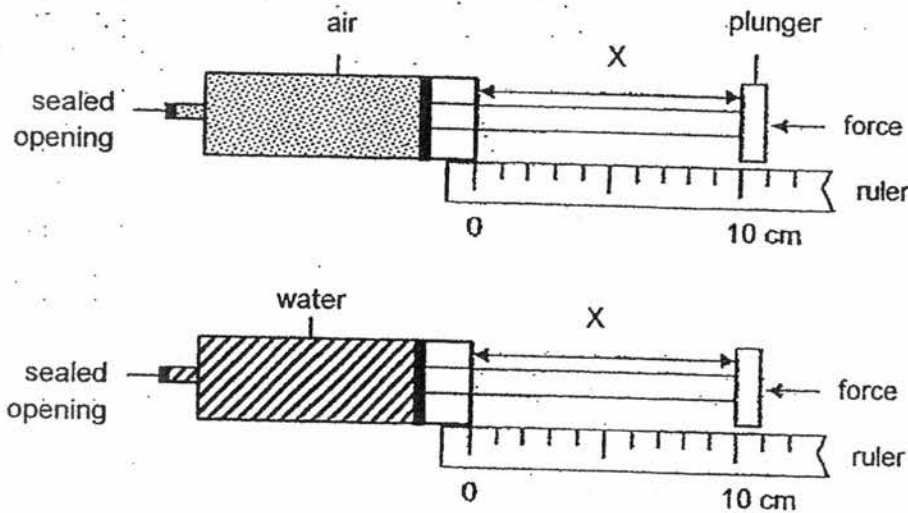

He then pushed each plunger as hard as he could and measured the distance, X. Which one of the following shows the correct values of X?

|     | Syringe with water (cm) | Syringe with air (cm) |
|-----|-------------------------|-----------------------|
| (1) | 10                      | 7                     |
| (2) | 10                      | 0                     |
| (3) | 7                       | 10                    |
| (4) | 5                       | 7                     |

17. Janet wants to find out if the temperature in an incubator affects the time taken for an egg to hatch. She used two incubators for her experiment. One of them is shown below.

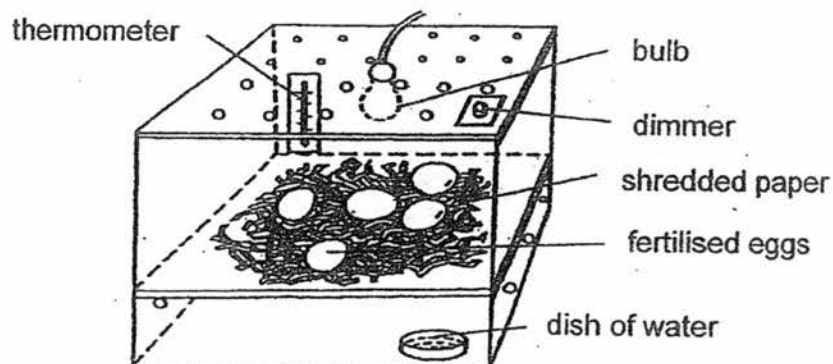

Which of the following variables must Janet keep constant for both incubators to ensure a fair test?

- A The type of egg.
  - B The temperature in the incubators.
  - C The time taken for the eggs to hatch.
  - D The amount of shredded paper in the incubators.
- (1) B only  
(2) A and D only  
(3) C and D only  
(4) A, B, C and D

18. An ice cube was placed in a sealed plastic container. After a while, the ice cube starts to melt as shown in the diagram below.

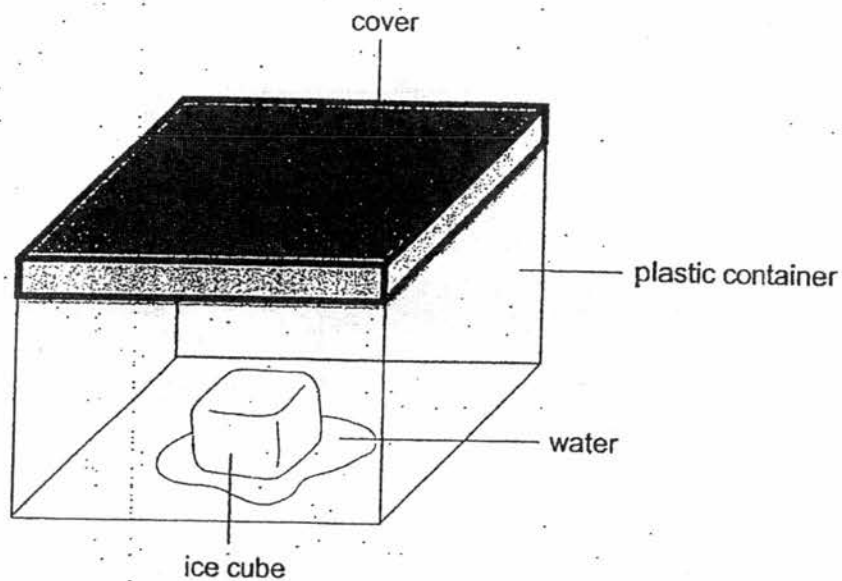

Which one of the following correctly states if heat is gained or lost by the ice cube, water and air in the container?

|     | Ice cube   | Water      | Air in the container |
|-----|------------|------------|----------------------|
| (1) | loses heat | loses heat | gains heat           |
| (2) | loses heat | gains heat | loses heat           |
| (3) | gains heat | gains heat | loses heat           |
| (4) | gains heat | loses heat | gains heat           |

19. Peter placed magnets A, B and C, on rollers as shown below.

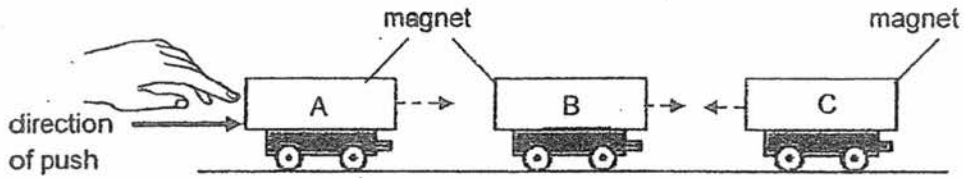

The arrow ( -> ) shows the direction in which the rollers move when magnet A was pushed towards magnet B.

What can he infer from his observations?

- (1) The like poles of magnet A and B are attracting each other.
  - (2) The like poles of the magnet B and C are attracting each other.
  - (3) The unlike poles of the magnet A and B are facing each other.
  - (4) The unlike poles of the magnet B and C are facing each other.
20. In the set-up below, when the circuit is closed, the bar magnet is repelled by the electromagnet and the pointer attached to the spring moves.

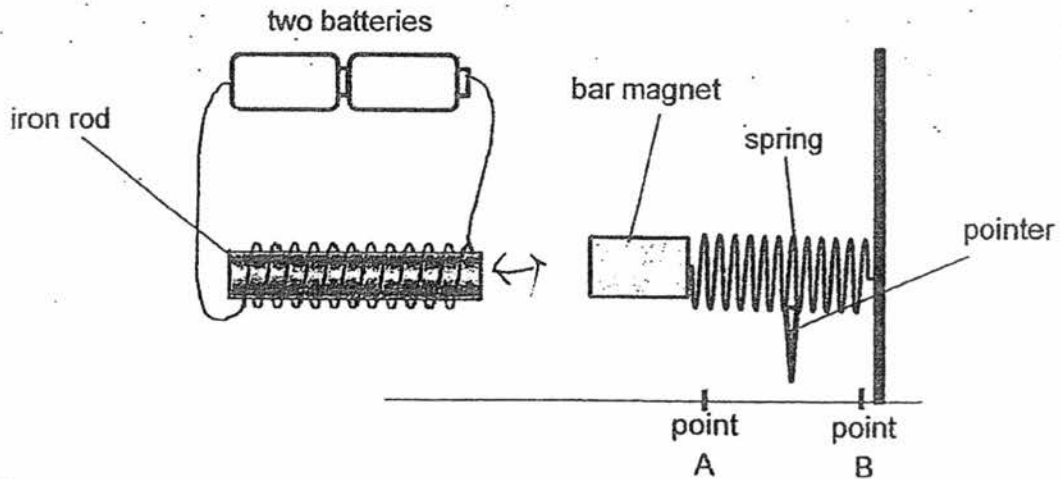

Which one of the following states correctly the movement of the pointer based on the change made to the set-up?

|     | Change to the set-up                         | Movement of pointer |
|-----|--|---------------------|
| (1) | Remove one battery                           | Towards point B     |
| (2) | Add one more battery                         | Towards point A     |
| (3) | Increase the number of coils on the iron rod | Towards point A     |
| (4) | Decrease the number of coils on the iron rod | Towards point A     |

21. The diagram below show two containers with 4 different blocks A, B, C and D.

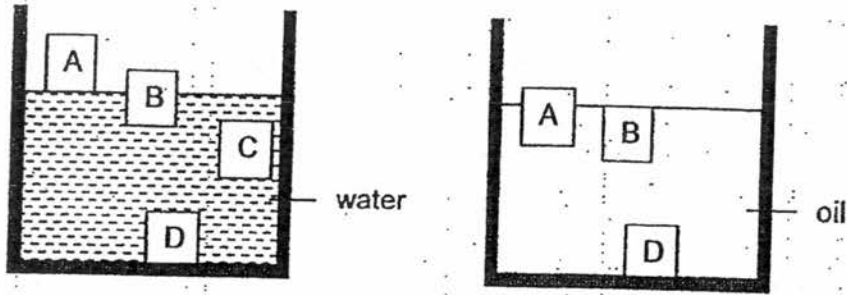

Which one of the following shows the most likely position of block C when it is placed in the container of oil?

|            |            |
|------------|------------|
| <p>(1)</p> | <p>(2)</p> |
| <p>(3)</p> | <p>(4)</p> |



22. Two marbles, A and B, were dropped from the same height. Marble A has a greater mass than marble B. Which one of the following graphs correctly represents how kinetic energy changes as they move downwards before they hit the ground?

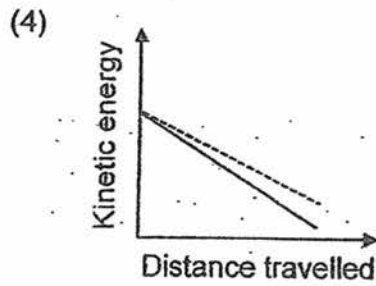
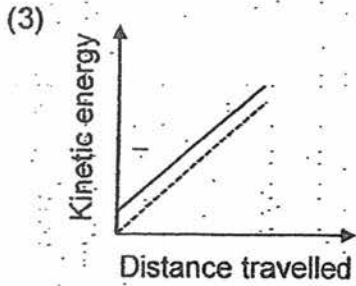
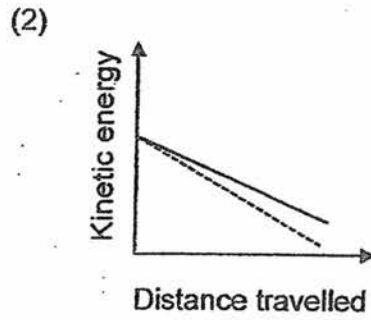
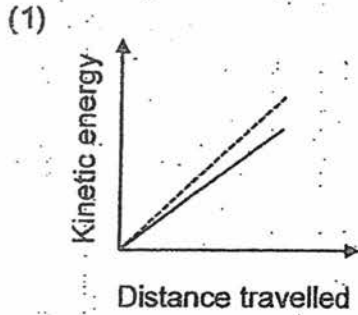
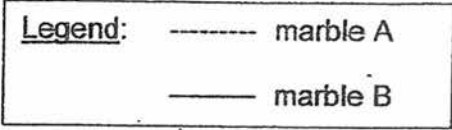

23. Four similar blocks of iron were heated to a temperature of 70 °C. Each block was then dropped into a beaker of water as shown in the diagram below. The beakers contained different amounts of water at different temperatures.

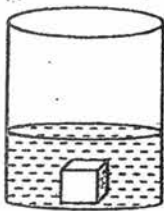

beaker A  
50 ml  
20 °C

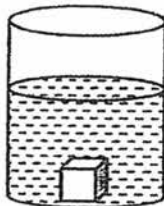

beaker B  
100 ml  
20 °C

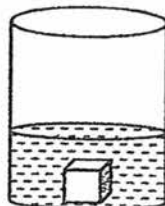

beaker C  
50 ml  
70 °C

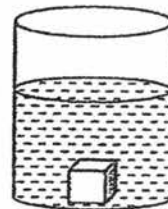

beaker D  
100 ml  
70 °C

In which beaker would the water show the greatest increase in temperature?

- (1) Beaker A
- (2) Beaker B
- (3) Beaker C
- (4) Beaker D

24. The diagram below shows a roller coaster.

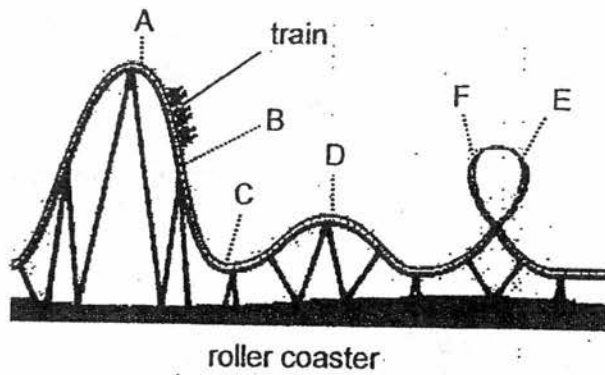

At which part of the track does the train have the most kinetic energy?

- (1) AB
- (2) BC
- (3) CD
- (4) EF

25. The table below shows the energy source of four power stations, A, B, C and D. Which power station is the least environmentally friendly?

| Power station | Energy source |
|---------------|---------------|
| (1) A         | oil           |
| (2) B         | sun           |
| (3) C         | wind          |
| (4) D         | running water |

26. Which one of the following is not a renewable energy source?

- (1) wind
- (2) natural gas
- (3) water
- (4) sunlight

27. Which one of the following activities does not involve a pushing force?

- (1) Kicking a ball away
- (2) Stopping a moving ball
- (3) Placing a pen on the table
- (4) Dragging a boat out of the water

28. Look at the activities shown below.

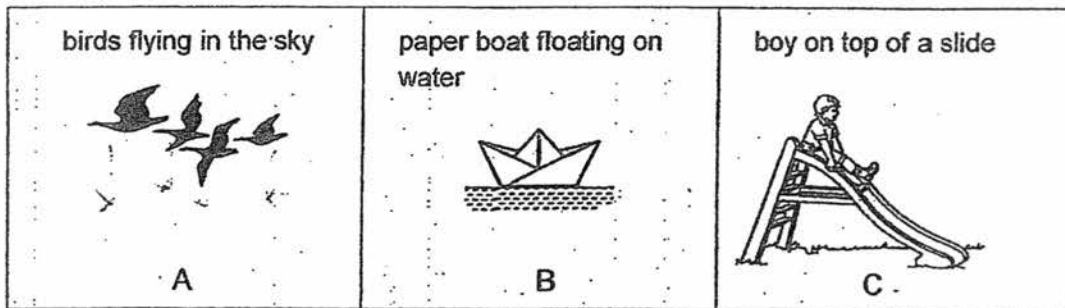

Which of the above show(s) the force of gravity at work?

- (1) C only
- (2) A and B only
- (3) B and C only
- (4) A, B and C

~~ End of section A ~~

Name: \_\_\_\_\_ ( )

Class : Primary 6 \_\_\_\_\_

**Primary 6**  
**Continual Assessment 1 – 2017**  
**SCIENCE**  
**BOOKLET B**  
**2 March 2017**

**Total Time for Booklets A and B: 1 hour 45 minutes**

**13 questions**  
**44 marks**

**Do not open this booklet until you are told to do so.**  
**Follow all instructions carefully.**

|           |     |
|-----------|-----|
| Booklet A | 56  |
| Booklet B | 44  |
| Total     | 100 |

*This booklet consists of 17 printed pages.*

**Section B: 44 marks**

For questions 29 to 41, write your answers in this booklet.

The number of marks available is shown in the brackets [ ] at the end of each question or part question.

29. The diagram below shows flower P.

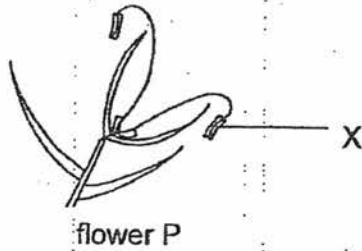

- (a) Which organ of the human reproductive system has a similar function as part X of flower P? [1]

\_\_\_\_\_

- (b) Part X is dangling outside the flower. What is the advantage of having this plant part outside the flower? [1]

\_\_\_\_\_  
\_\_\_\_\_

- (c) Based on the above diagram, will flower P be able to develop into a fruit? Explain your answer. [1]

\_\_\_\_\_  
\_\_\_\_\_

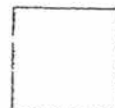

30. Johanna carried out an experiment to find out the effect of temperature on the rate of photosynthesis of the hydrilla as shown in the diagram below. The set-ups were left under the same light source for a few minutes.

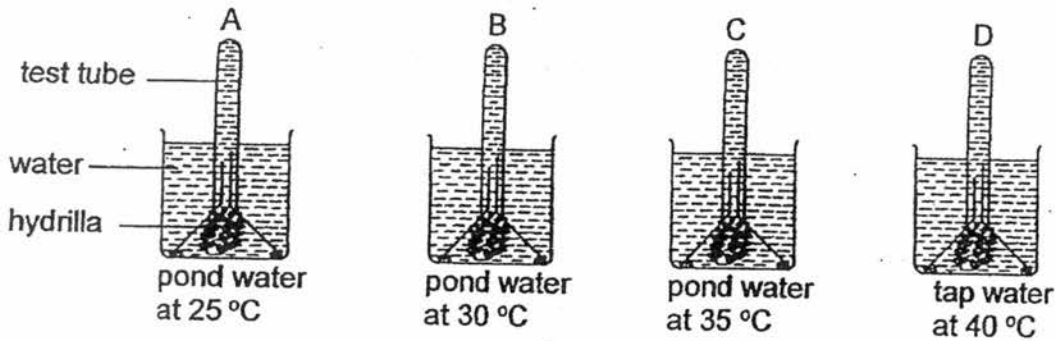

- (a) What could she measure in order to find the rate of photosynthesis of the hydrilla?

- (b) Did she carry out a fair experiment? Explain your answer.

The graph below shows the relationship between the rate of photosynthesis of the hydrilla plant and the temperature of the water.

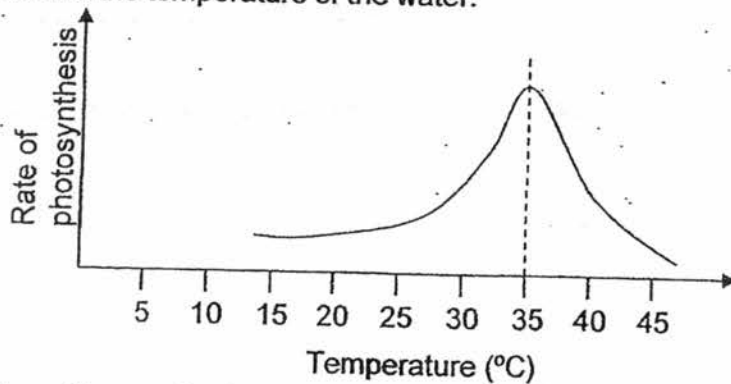

- (c) Based on the graph above, what conclusion can you draw about the effect of temperature on the rate of photosynthesis? [2]

- (d) Temperature of the water in Pond Q can reach as high as 40 °C around noon time. Based on the graph above, explain why fish in Pond Q are usually found near the water surface around noon time? [1]

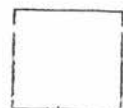

31. The diagram below shows fruits with different methods of dispersal.

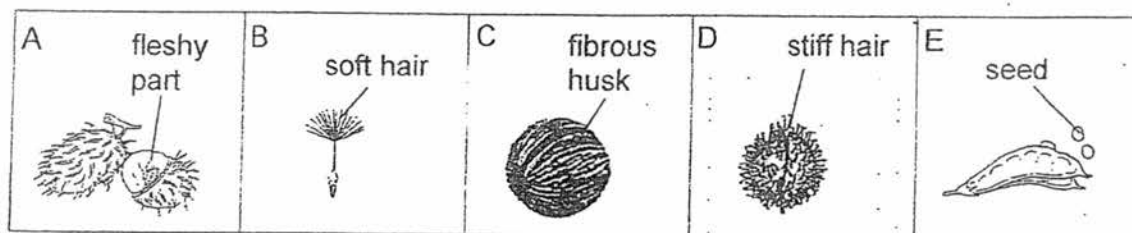

(a) Based on the diagram above, classify the fruits by writing the letters, A, B, C, D and E, in the classification table below. [2]

| Methods of dispersal |       |         |           |
|----------------------|-------|---------|-----------|
| Wind                 | Water | Animals | Splitting |
|                      |       |         |           |

(b) Siti found an African Tulip fruit in the school compound. Her teacher told her that the fruit should be classified under two of the above groups.

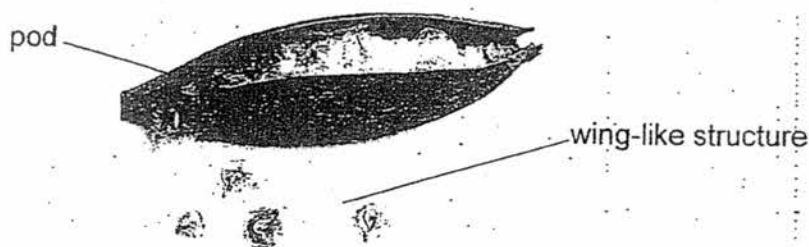

Why did her teacher say that?

[1]

---



---

(c) In the graph below, **draw** clearly a line graph to show the relationship between the number of seeds dispersed by **Fruit A** and the strength of the wind. [1]

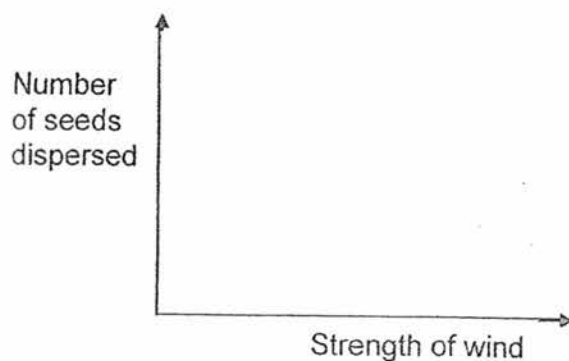

32. The bar graph below shows the concentration of oxygen in four blood samples taken at the same time from different blood vessels located in different parts of the circulatory system.

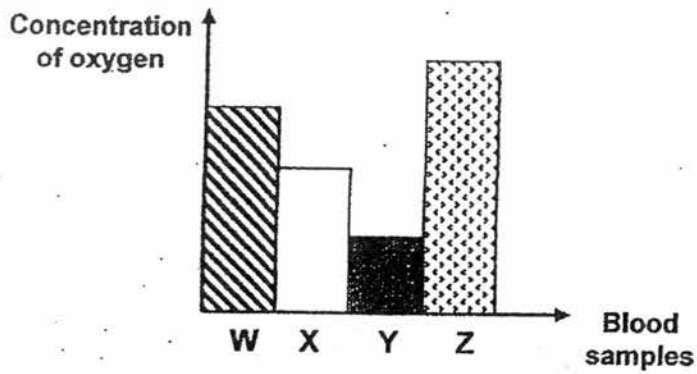

The following diagram shows the different organs linked with different blood vessels.

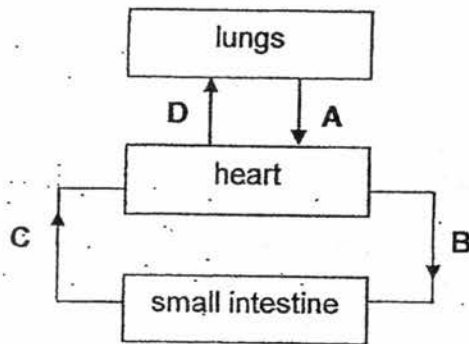

- (a) Fill in, A, B, C and D, in the table below to show how the different blood vessels are matched with the blood samples. [2]

| Blood Sample | Blood vessel from |
|--------------|-------------------|
| W            |                   |
| X            |                   |
| Y            |                   |
| Z            |                   |

- (b) What role does the circulatory system play in the digestion of food? [1]

---



---

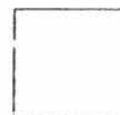



33. Shawn set up a circuit as shown. When he closed the switch, the hammer will hit the gong.

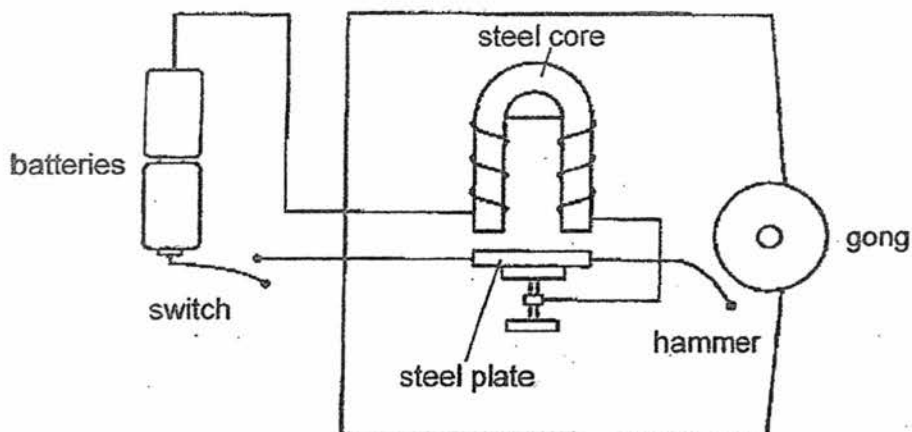

- (a) Explain why the hammer was able to hit the gong when Shawn closed the switch? [1]

---

---

---

- (b) Shawn replaced the steel plate with another plate made of a different material. When he closed the switch, the hammer did not move at all. Based on the result above, state a possible material the plate could be made of and write down one property of the material. [1]

---

---

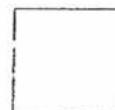

34. The set-up below shows light shining on four objects, A, B, C and D, made of different materials. They are placed at different distances from the torch.

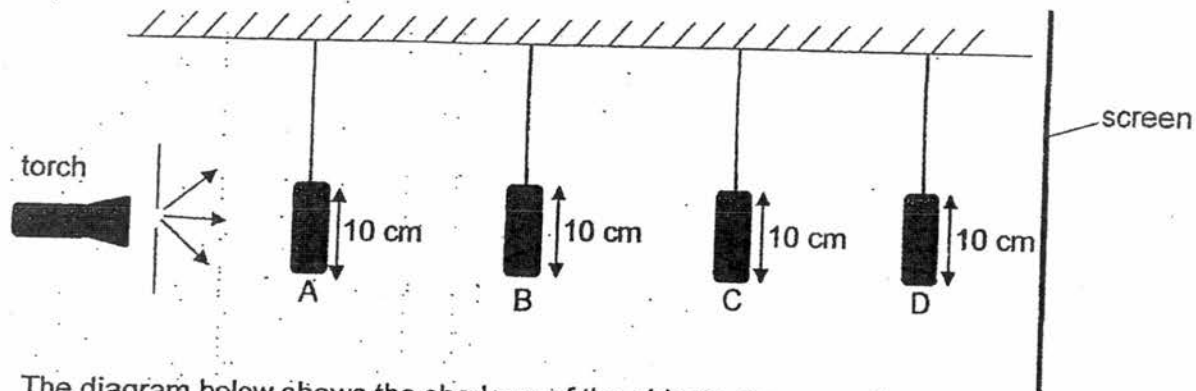

The diagram below shows the shadows of the objects shown on the screen.

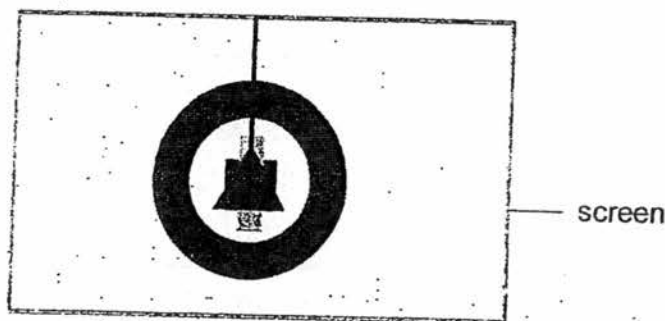

- (a) Based on the shadows formed, identify the objects A, B, C and D.

[2]

| Shapes    | Object |
|-----------|--------|
| Ring      |        |
| Square    |        |
| Triangle  |        |
| Rectangle |        |

- (b) It was observed that the triangular shadow cast was darker than the rectangular shadow cast. What could be a possible reason for the difference?

[1]

---



---

- (c) State one property of light that allows shadows to be formed.

[1]

---



---

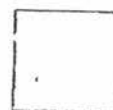

35. Sue conducted an experiment where she placed a flame near one end of a hollow glass tube that was sealed at both ends. Two holes were drilled and two thermometers were inserted at points A and B as shown in the diagram.

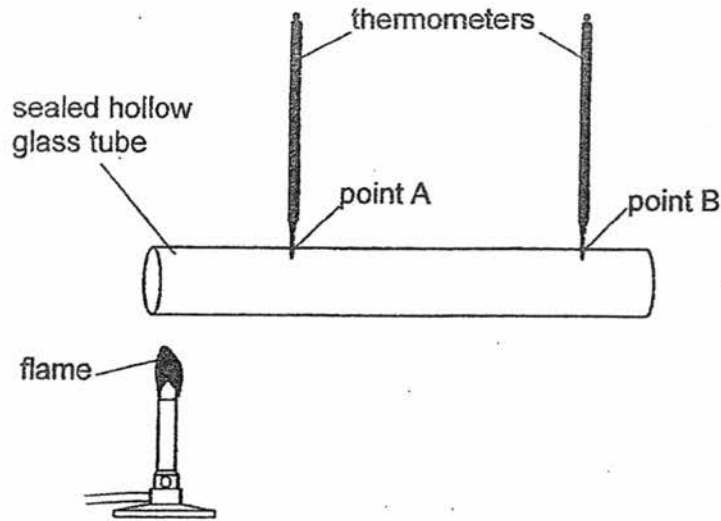

She recorded the temperature of air in the hollow tube at point A and B every 2 minutes in the table shown below.

| Time (min) | Temperature of air at |              |
|------------|-----------------------|--------------|
|            | Point A (°C)          | Point B (°C) |
| 0          | 28                    | 28           |
| 2          | 40                    | 30           |
| 4          | 52                    | 35           |
| 6          | 60                    | 39           |

- (a) What is the relationship between the duration of heating and the temperature of air at point A? [1]

---



---

- (b) Based on the results recorded, explain why the temperature at point B increased slower than the temperature at point A. [1]

---



---

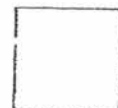

- (c) How will the results be affected if the glass tube is replaced with a metal tube? [1]

---

---

The diagram below shows a cross-section of a double-layered glass window of an aeroplane.

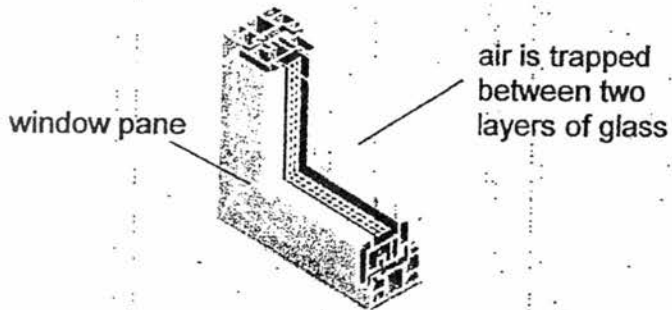

As the aeroplane flies higher up to the sky, the temperature outside the aeroplane decreases to below  $0^{\circ}\text{C}$ .

- (d) Explain how such windows help passengers remain warm in the aeroplane. [1]

---

---

---

---

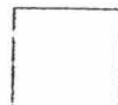

36. Raja conducted an experiment using string X in the set-up below.

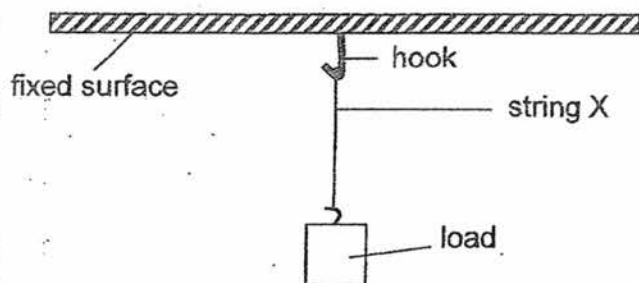

He increased the mass of the load until string X broke. He then recorded the mass and repeated his experiment with two other strings, Y and Z. The results of his experiment are shown in the table below.

|          | Mass of load hung when the string broke (g) |
|----------|---|
| String X | 1000  |
| String Y | 500   |
| String Z | 1450  |

(a) What is the aim of Raja's experiment? [1]

---

---

(b) What can Raja do to ensure that the results of his experiment are reliable? [1]

---

---

---

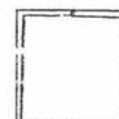

37. Hassan conducted an experiment with three different models of aeroplanes X, Y and Z.

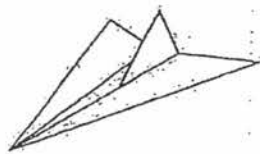

model X

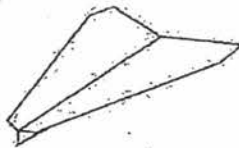

model Y

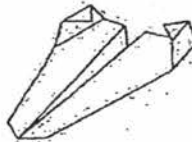

model Z

He launched each model aeroplane horizontally with the same amount of force from the same height. He recorded the time taken for each model to reach the ground in the table below. He repeated his experiment two more times.

| Model   | X                   |                     |                     | Y                   |                     |                     | Z                   |                     |                     |
|---------|---------------------|---------------------|---------------------|---------------------|---------------------|---------------------|---------------------|---------------------|---------------------|
|         | 1 <sup>st</sup> try | 2 <sup>nd</sup> try | 3 <sup>rd</sup> try | 1 <sup>st</sup> try | 2 <sup>nd</sup> try | 3 <sup>rd</sup> try | 1 <sup>st</sup> try | 2 <sup>nd</sup> try | 3 <sup>rd</sup> try |
| Time(s) | 3.4                 | 3.4                 | 3.5                 | 4.8                 | 4.9                 | 4.8                 | 2                   | 2.1                 | 2.1                 |

- (a) What was the aim of his experiment? [1]

---

- (b) Name one other variable Hassan should keep constant for his experiment to be fair. [1]

---

- (c) Based on Hassan's results, which one of the models, X, Y or Z, should he use to design a toy aeroplane that can fly the furthest distance? Explain your answer. [1]

---



---

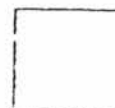

38. Karen magnetised a steel bar AB using the stroking method as shown in diagram 1 below. Diagram 2 shows the magnetic poles of the steel bar AB after it was magnetised.

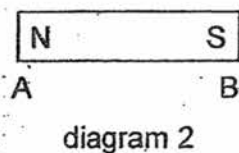
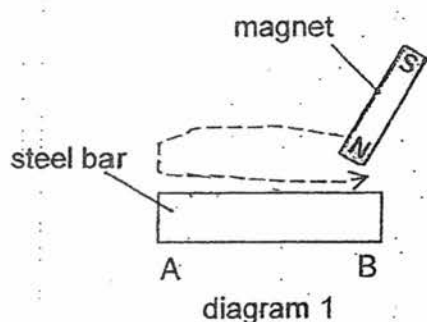

Another steel bar CD was magnetised using two magnets as shown in diagram 3 below.

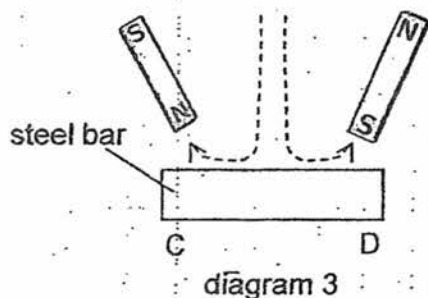

- (a) State what the magnetic poles of the steel bar CD would be at end C and D.

[1]

At end C: \_\_\_\_\_

At end D: \_\_\_\_\_

- (b) Using **only** bar CD and a magnet, how can Karen confirm that bar CD is magnetised?

[1]

---



---

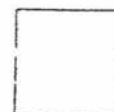

Karen then took the two steel bars, AB and CD, and hung them above a tray of iron nails as shown below.

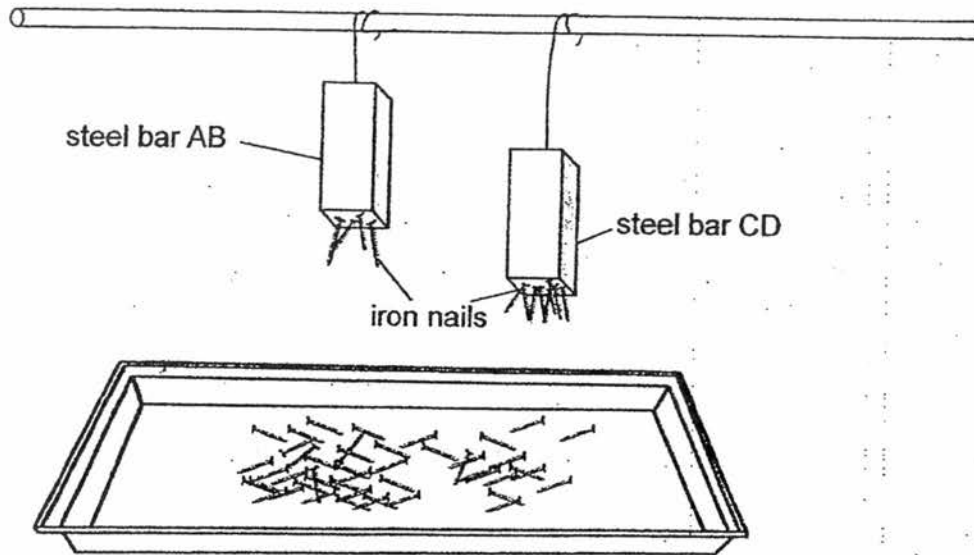

- (c) From the observation above, is Karen able to conclude which steel bar, AB or CD, has a greater magnetic strength? Explain your answer.

[1]

---

---

---

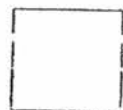



39. A pot of water is heated on a hot metal plate as shown below.



(a) Which of the following is correct when the water boils? Tick the correct statement(s) in the box below.

[1]

| Statement   | Tick if it is correct |
|---|-----------------------|
| Steam can be seen forming above the water.                        |                       |
| The temperature of the water remains constant.                    |                       |
| The transfer of heat from the metal plate to the water will stop. |                       |

Corrine placed two identical pots containing the same amount of water at room temperature on two electrical metal plates. The metal plates are made of the same material but with different surfaces as shown below.

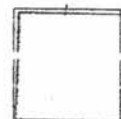
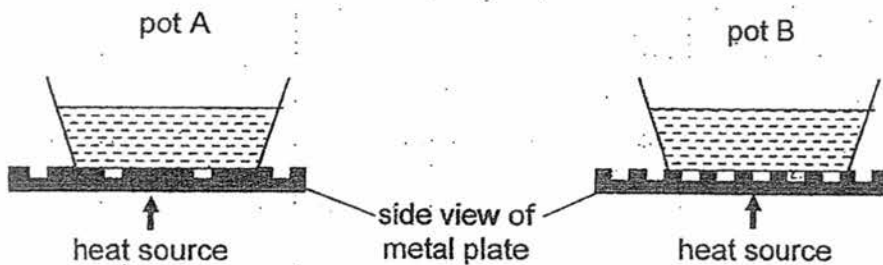

- (b) Corrine recorded the time taken for the water in both pots to boil and plotted the results of pot A on the graph below. On the same graph, draw another line to represent the results of pot B.

[1]

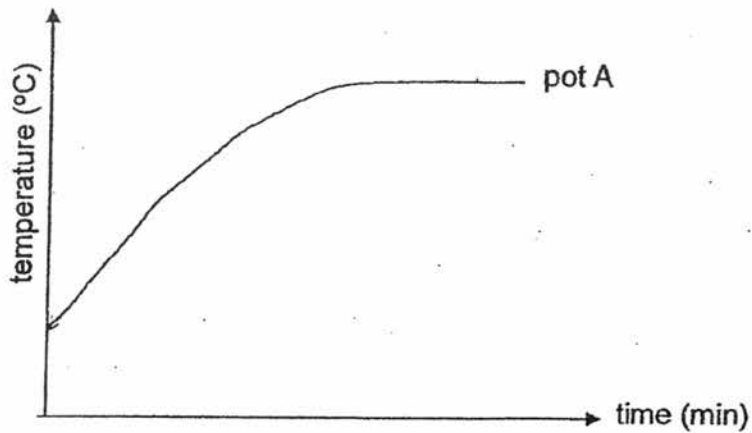

- (c) Give a reason for your answer in (b).

[2]

---



---



---

Corrine wants to find out if the thickness of the metal plate will affect the time taken for the water to boil. She sets up another experiment as shown below:

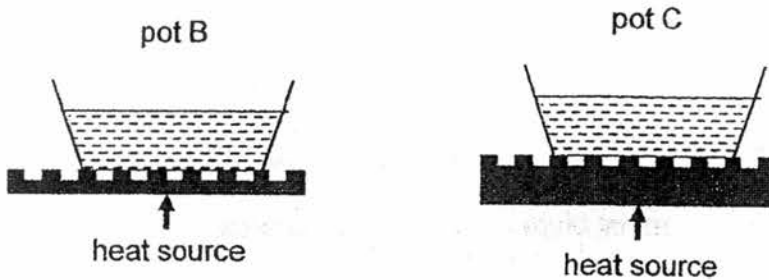

- (d) Corrine thinks that the thickness of the metal plate does not affect the results of the experiment. Is she correct? Explain your answer.

[1]

---



---



---



40. The chart below shows the process of using coal to produce electricity in a power station.

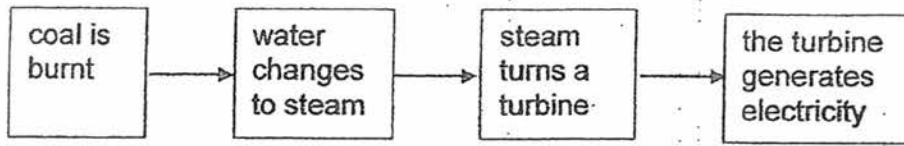

(a) What is the main energy transfer when coal is burnt? [1]

---

(b) Some of the energy stored in coal is wasted when it is burnt.  
Name one type of energy released that is not useful in the above process. [1]

---

(c) Suggest one disadvantage of using coal to generate electricity. [1]

---



41. Electricity can be generated using wind turbines. An example of a wind turbine is shown below.

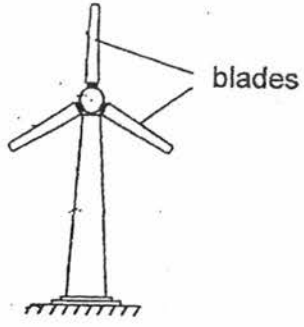

The graph below shows the amount of electrical energy produced by different wind turbines. The blades of the wind turbines are of different lengths.

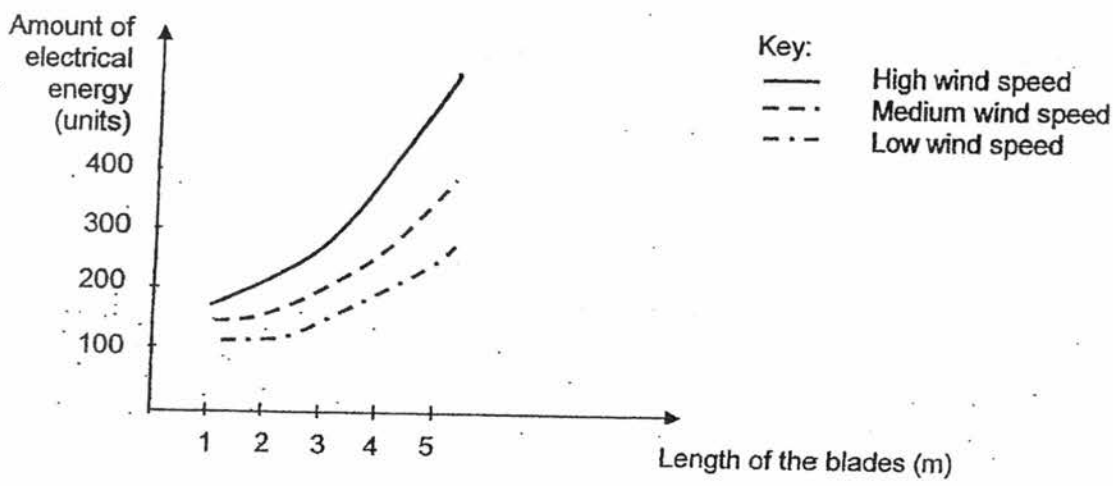

(a) From the graph, state 2 conditions that can cause the wind turbines to produce more electrical energy. [2]

---



---



---

(b) Write down the main energy conversion that takes place as the wind turbine spins. [1]

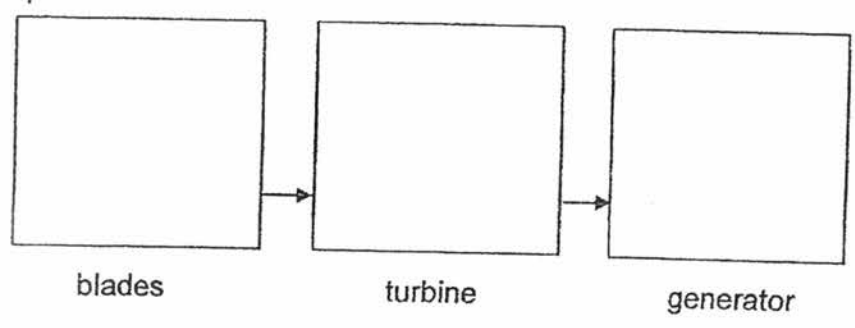

--- End of paper ---

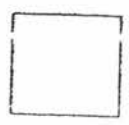

EXAM PAPER 2017      2 March 2017  
 LEVEL : PRIMARY 6  
 SCHOOL : CHIJ ST NICHOLAS GIRL'S SCHOOL (PRIMARY)  
 SUBJECT : SCIENCE  
 TERM : CONTINUAL ASSESSMENT 1

|     |     |     |     |     |     |     |     |     |     |
|-----|-----|-----|-----|-----|-----|-----|-----|-----|-----|
| Q1  | Q2  | Q3  | Q4  | Q5  | Q6  | Q7  | Q8  | Q9  | Q10 |
| 3   | 2   | 1   | 2   | 1   | 2   | 4   | 3   | 3   | 1   |
| Q11 | Q12 | Q13 | Q14 | Q15 | Q16 | Q17 | Q18 | Q19 | Q20 |
| 4   | 2   | 4   | 2   | 3   | 1   | 2   | 3   | 4   | 4   |
| Q21 | Q22 | Q23 | Q24 | Q25 | Q26 | Q27 | Q28 |     |     |
| 2   | 1   | 1   | 2   | 1   | 2   | 4   | 4   |     |     |

Q29a) Testis

b) The pollen grain on the anther can be easily blown away by wind to another flower of the same species for pollination.

c) No. Flower P does not have an ovary and an ovule, so it cannot be fertilized and develop into a fruit.

Q30a) She can measure how many bubbles the hydrilla produced.

b) No. She did not use the same type of water.

c) 35°C is the best temperature for photosynthesis, also, the rate of photosynthesis increases from 15°C to 35°C, but decreases after 35°C and above.

d) In noon, the rate of photosynthesis is slower, and will not give out much oxygen for the fish, and the fish swim near the water surface for more oxygen.

Q31a) Wind: B      Water: C      Animals: A,D      Splitting: E

b) The pod has a hard shell which explodes the seeds away from the parent plant and is classified as splitting dispersal but the seeds also have wind-like structures to float away, hence being classified also as wind dispersal

c)

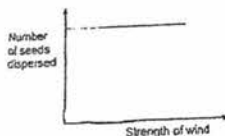

Q32a) W - B      X - C      Y - D      Z - A

b) It circulates the nutrients of the digested food to other parts of the body.

Q33a) When the switch is closed, the steel core will be an electromagnet, attracting the steel plate which is connected to the hammer, which moved upwards and will hit the gong.

b) Wood. Wood is not a conductor of electricity.

Q34a) Ring - A      Square - D      Triangle - C      Rectangle - B

b) The triangular block is made out of an opaque material while the rectangular object is made out of a translucent material.

c) It travels in a straight line.

Q35a) As the duration of heating increases, the temperature of air at point A increases.

b) Point A is closer to the flame, and the glass tube will gain heat first at the point.

c) Point A and Point B will gain heat faster.

d) Air between the windows will slow down heat loss between the warmer air inside the aeroplane and cold air outside the aeroplane as it is a poor conductor of heat.

Q36a) To find out which string is the strongest.

b) He can repeat the experiment multiple times and average the results.

Q37a) To find out which airplane model reaches the ground first.

b) The amount of wind in where the experiment is taking place.

c) Model Y. It took the longest time to land on the ground compared to X and Z.

Q38a) At end C: South Pole      At end D: North pole

b) She can make the like poles of both magnets facing each other, if they repel, CD is magnetised.

c) No. Bar CD is nearer to the nails and attracted more nails than Bar AB.

Q39a) The temperature of the water remains constant.

b)

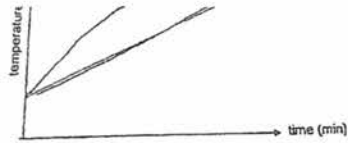

c) Pot B has a smaller surface in contact with the metal plate so less heat will be gained by the water in pot B, so water in pot B will boil slower than pot A.

d) She is not correct. The thicker the metal plate, the slower the rate of gaining between the heat source and the plate, which affects the rate of the pot gaining heat, hence affecting the experiment.

Q40a) Chemical potential energy  $\rightarrow$  heat energy

b) Light energy

c) Coal is unrenewable.

Q41a) Higher wind speed and longer blades.

b) Kinetic energy  $\rightarrow$  kinetic energy  $\rightarrow$  electrical energy

3.

END.

